





Fluid transport of the products

The transport of containers and products from a machine to another one within a bottling line is a crucial factor in order to ensure high performance standards.

This procedure must be fluid and constant and must guarantee the maximum operating flexibility, in order to face sudden flow changes, due to unexpected conditions during the machines operation.

To this purpose, a last generation automation and control system, as well as sophisticated sensors, ensure high performance standards during all phases of the production cycle.



Smiline logistic systems are designed to fully meet the exigencies of fluidity, flexibility and efficiency, thanks to innovative technical solutions and top quality materials:

- modular structure which can easily fit several types of containers and product flows
- minimization of the changeover times, in order to quickly switch from a production to another one
- high operational reliability, thanks to stainless steel AISI 304 frame and components
- friction and noise levels among the lowest in this sector
- reduced need of maintenance and cleaning interventions, restricted to a few sections
- easy and intuitive start and control operations
- user-friendly technology, thanks to the POSYC operator panel with LCD touch screen
- energy consumption and operational costs among the lowest of the market

Smiline solutions can guarantee an optimal control of the product flows, thanks to an accurate study of the accumulation, distribution and transport dynamics.

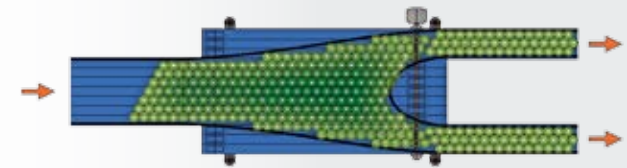

Smiline offers customized solutions for a quick and trouble-free transfer of empty PET containers of any shape and size from the blow molder to the filler.

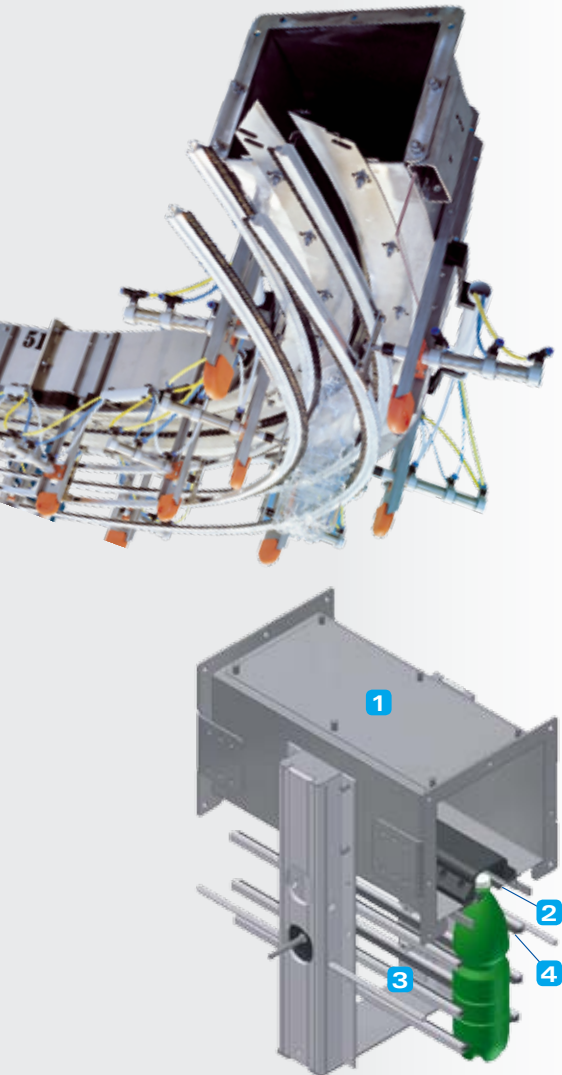

» Modular and ergonomic design

Smiline air conveyors feature a modular design and a great operational flexibility, also thanks to the use of frequency converters (inverters) which optimize the conveyors speed. Furthermore, the stainless steel AISI 304 frame (1) makes the maintenance and cleaning operations easier. It is also possible to adjust the air distribution system according to the type of bottle, by means of manual valves or through the electronic control of the motors speed.

» Low maintenance and operating costs

The product guides (2) are made of stainless steel and plastic UHMW antifricition material, whereas the guides controlling the bottles trajectory (3) consist of non-abrasive, plastic brushes (4), with the following advantages:

- they preserve the container quality
- they grant the correct side position of every kind of bottle
- they reduce the changeover times
- they reduce the wear levels and the maintenance operations
- they offer great advantages from the economical point of view (minimized operational costs)

» Great flexibility for any kind of request

In order to ensure a high-quality air filtration, Smiline offers a wide range of philtres (G4, G3, F9, H14, etc.) UNI-EN779. Furthermore, thanks to a user-friendly control panel, the operator can easily select the guides position, according to the product format. Smiline air conveyors can be wall-mounted or hung to the ceiling, with great advantages from a logistic point of view.



CLASSIFICATION	CONFIGURATION	DESCRIPTION
G4	G4 > FAN	Standard Filtration
H14	G3 > FAN > F9 > H14	Aseptic Efficiency Filtration



Conveyors for loose products or bundles



» Top-quality, wear-resistant components

Made of stainless steel AISI 304, Smiline conveyors feature a wide range of chains, in order to optimize the transport of plastic/glass bottles and cans, and several types of rollers ensuring fluid and regular movements, in order to avoid damaging the conveyed products. The use of top-quality components, together with wear-resistant materials, minimizes the friction and the noise and makes the maintenance operations easier, with a quality/price ratio among the best in the sector.

» User-friendly technology

Smiline conveyors are very easy to use, both during the production cycle and during the maintenance operations. In fact, any intervention to be performed by the operator is very simple and intuitive thanks to the POSYC control panel with LCD colour touch-screen. Furthermore, the automation of the movements ensures an optimal control of the product flow, according to the operation parameters of the whole line.



Smiline offers innovative systems for the transport of loose containers, bottles or cans and for clustered products, bundles and cardboard cases.

» **Total compatibility with other systems**

Thanks to the modular design, to the “mechatronic” architecture and to the high compatibility with other systems, it is easier to integrate Smiline conveyors in several kinds of bottling and packaging lines, already existing or still to be designed; moreover, the installation, start-up and commissioning operations are simplified.

» **“ Friction-rollers ” system**

Among the available options, Smiline conveyors can be equipped with the “friction-rollers” system, an ideal solution for the transport of bundles on the linear stretches. This system offers a compact, uniform sliding platform, thanks to a sequence of closely-woven rollers, made of stainless steel, with 18 mm diameter; it offers great advantages, such as a reduced wear of the components, a more fluid product flow, easier and reduced maintenance and cleaning operations.

» **Automatic nozzle lubrication**



Smiline conveyors are lubricated by an automatic nozzle lubrication system, which minimizes the noise level, the operational costs and the cleaning interventions. It can be supplied “oil free” or

“water free”, according to the customer’s exigencies.

Types of conveyors for loose products



Types of conveyors for bundles

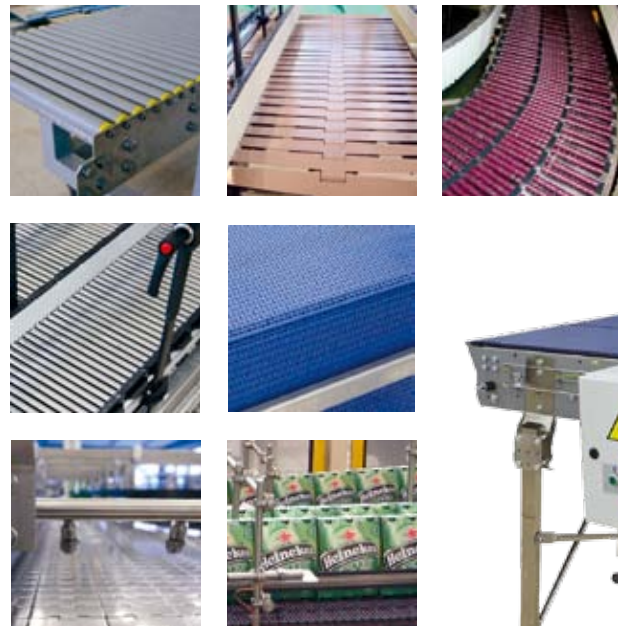

» **Additional cooling conveyor and pack turning device**

At the outlet of the shrink tunnel of shrinkwrappers, it is possible to install an additional conveyor, equipped with a fan, which allows a quicker cooling of the shrunk bundles, in order to obtain immediate stiffening.

This accessory prevents any deformation of the bundles coming out of the machine, especially during the transfer onto the conveyors and during the palletization operations.

It is an ideal solution for high-speed lines: it can be 800 or 1500 mm long and can be equipped with the pack turning device, for specific packaging exigencies.

This accessory, designed for turning the packs from the short side leading to the long side leading or vice versa, can be used with bundles in film only, trays and cardboard cases.

The use of plastic chains eliminates frictions and wear of the conveyed product.

It is available with differentiated speed chains and with contrast pivots.



Dividers

» DV – GDV series dividers

The distribution of the containers within a production line is made possible by the dividers of the "DV" and "GDV" series. The "DV" dividers receive the loose product in single row, they divide it into several rows and lane it towards the secondary packaging machines. At present, two models are available:

- alternating motion DV 200, with a maximum output of 350 containers per minute (*)
- continuous motion DV 500, with a maximum output of 750 containers per minute (*)

By contrast, the "GDV 500" dividers can receive the products on several infeed rows (up to 4) and divide them into several rows at the outlet (up to 6), with a maximum output of 750 containers per minute (*)

(*the outputs are referred to a ø 50 mm PET container).

» Reliability and duration

Smiline dividers are made of top-quality materials, ensuring operating reliability and long-term duration. The use of wear-resistant components minimizes the maintenance and cleaning operations, thus reducing the total operating costs.



Smiline offers compact, flexible systems for dividing and lanning bundles and containers of non-cylindrical shape.

» Plate divider

The plate divider is used for dividing the packs coming out of the automatic packaging machines, in order to lane them into several rows by



means of a translation device, with a maximum output of 80 packs per minute.



Conveyors Automation: VaryLine System

The automation and supervision of Smiline conveyors are controlled by the VLS (VaryLine System) PRO, an advanced hw/sw system designed by SMI and based on PROFIBUS field bus.

The VLS PRO can control up to 121 inverter-equipped motors and integrates in a single control unit both the PC controlling the conveyor line and the multi-language man-machine interface. Furthermore, the control unit can be positioned in the most strategic point within the line, thanks to its reduced size.

» Automation and control at customer's disposal

The conveyor systems manufactured by SMI offer several advantages for the end user, thanks to the innovative technology used for the automation and control of the system operations. Among the main features, the following ones are worth mentioning:

- reduced costs, thanks to a distributed architecture based on inverters with integrated motor, requiring less space for the electrical panels and simplifying the wiring
- user-friendly technology, thanks to the use of only one industrial PC (POSYC) combining the functions of control unit and of operator interface
- reduced size of the control unit, which can be positioned in the most strategic point within the line
- line wiring costs and times among the lowest of the category
- modularity, allowing to install several VLS units within the same system
- operating flexibility and quick changeover
- reduced maintenance operations
- multi-language man-machine interface
- low energy consumption

» User-friendly technology

From the POSYC VLS control unit with LCD touch screen, the operator can perform several operations, such as:

- set the conveyors operation parameters
- adjust the conveyors speed according to the product flow and type
- stop the conveyors and start them again automatically, according to the required product flow
- collect the production data
- plan the maintenance operations



» Design of integrated systems

SMI is specialized in the design of integrated systems for the bottling and packaging of food and beverage products in plastic containers (PET, HDPE, PP), glass containers or cans. According to the customer's need, SMI develops a project including:

- preliminary study
- feasibility study and assessment of all logistic aspects which might influence the performances and the global outputs
- accurate analysis of the costs dynamics (TCO - Total Cost of Operation)
- 3D graphic simulation of the systems operation, through the "Virtual Factory"
- detailed study of the interactions between the machines and the devices constituting the line; accurate selection of the machines manufactured by SMI and of those manufactured by other OEM (Turnkey systems)
- global control of the project, based on the "Product LifeCycle Management" principles, in order to plan, solve, maintain and improve the performances of the supplied systems, during their whole life cycle

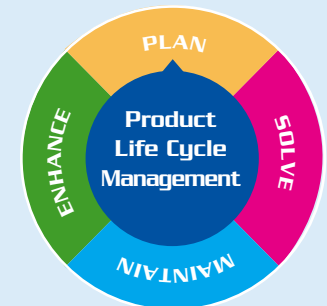
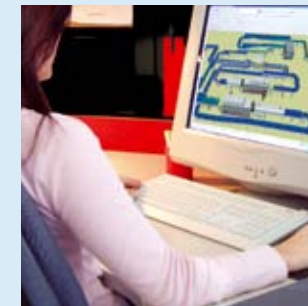

www.smigroup.it



SMI S.p.A. - Headquarters
Via Piazzalunga, 30
IT-24015 San Giovanni Bianco (BG)
Tel.: +39 0345 40.111 - Fax: +39 0345 40.209
info@smigroup.it

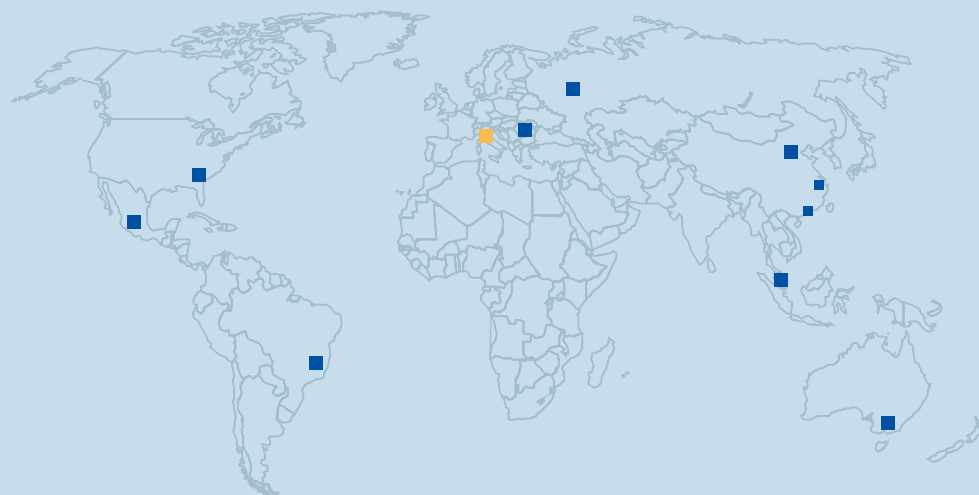

DP010275

